

DeltaQualifikationsMatrix

Allgemeines

Kurze Produkt- und Technologiezyklen elektronischer Bauelemente sowie neue Umweltauflagen (Bleiverbot, Flammschwermetalle, ...) führen häufig zu prozess- und werkstofftechnischen Änderungen an Bauelementen, Leiterplatten, Verbindungstechnik und Schaltung, welche evaluiert werden müssen. Eine geeignete Methodik zur Handhabung von Änderungen an elektronischen Bauelementen beschreibt die ZVEI "Guideline for Customer Notifications of Product and /or Process Changes (PCN) of Electronic Components specified for Automotive Applications". Ein wesentlicher Teil dieser Guideline sind die hier vorliegenden Matrizen, welche sich als Empfehlungen für die Evaluierung von typischen Änderungen an elektronischen Bauelementen verstehen. Dies sollte Teil des offenen und risikobewussten Dialoges zwischen Lieferant und Kunden sein. Diese DeltaQualifikationsMatrizen wurden durch den Industriearbeitskreis "PCN DeltaQualifikationsMatrix" und den Bauteilexperten des ZVEI Arbeitskreises "PCN-Methodik" erarbeitet. Der Inhalt wurde basierend auf dem aktuellen Stand der Technik erstellt und erhebt keinen Anspruch auf Vollständigkeit. Im Einzelfall ist ggf. ein abweichendes Vorgehen abzustimmen, da kundenspezifische Vereinbarungen zur Qualifikation zu berücksichtigen sind.

Anwendung der DeltaQualifikationsMatrix (auszufüllen durch den Bauelementhersteller)

- Diese Tabelle ist **nur** bei Änderungen anzuwenden. Neuqualifikationen und Sonderqualifikation (z.B. Verguß von Modulen) sowie Information Notes bleiben von diesen Matrizen unberührt.
- Ist eine Änderung in dieser Tabelle nicht aufgeführt, so ist der Qualifikationsumfang zwischen Kunde und Lieferant abzustimmen.
- Die Matrix der Aktiven Bauelemente ist so aufgebaut, dass zwischen integrierten Halbleitern (AEC-Q100 Rev.H) und diskreten Halbleitern (AEC-Q101 Rev. D1) auszuwählen ist (Zelle D4). Für Passive Bauelemente gilt die AEC-Q200. Für LED's gilt die IEC 60810.
- Alle** Änderungen in der PCN sind in der Spalte B durch ein Kreuz (x) zu markieren und werden dadurch farblich hervorgehoben. Sofern dies geschehen ist, werden im Feld "Tests, which should be considered for the appropriate process change" (Zelle 83 für Aktive Bauelemente, Zelle 466 für Passive Bauelemente oder in Zelle 77 für LED's) alle in Betracht zu ziehenden Zuverlässigkeitstests angezeigt.
- In "Tests, which should be considered for the appropriate process change after selection of condition table" (Zelle 85 für Aktive Bauelemente, Zelle 468 für Passive Bauelemente oder Zelle 79 für LED's) wird die Anpassung der in Betracht zu ziehenden Tests in Folge der Relevanz bezüglich der Änderung berücksichtigt. Dazu ist die Tabelle "Conditions" entsprechend der Auswahl (A/B/C) mit einem (x) zu bewerten.
- In "Suppliers performed tests" (Zelle 87 für Aktive Bauelemente, Zelle 470 für Passive Bauelemente oder Zelle 81 für LED's) dokumentiert der Bauelementhersteller die durchgeführten bzw. geplanten Tests.
- Falls von der Testempfehlung abgewichen wird, so sollten diese Abweichungen vom Bauelementhersteller angezeigt und kommentiert werden. Hierzu ist der Bereich "Reason for exception of tests" (Zelle 89 für Aktive Bauelemente, Zelle 472 für Passive Bauelemente oder Zelle 83 für LED's) zu verwenden. Werden die in Betracht zu ziehenden Tests durch generische Daten (G) belegt, ist dies ebenfalls hier anzuzeigen und zu begründen.

Die Einstufung des Untersuchungslevel erfolgt in folgende Kategorien

- *C: Component level***: Die Evaluierung der Änderung am Bauelement ist durch Untersuchungen **ausschließlich** am Bauelement beim Bauelementhersteller durchführbar. Zur Evaluierung der Änderung dürfen Ergebnisse aus bereits durchgeführten Untersuchungen herangezogen werden, wenn diese zu einem ähnlichen Bauelement bereits vorliegen (**Generische Daten**).
- *B: Board level***: Die beschriebene Änderung hat möglicherweise Einfluss auf die Verarbeitbarkeit des Bauelementes im Steuergerät. Die Evaluierung der Änderung wird wie unter C beim Bauelementhersteller durchgeführt. Zusätzlich ist durch den Kunden/Steuergeräthehersteller die Verarbeitbarkeit zu prüfen, die z.B. abhängig von der Änderung, Zuverlässigkeitsuntersuchungen auf applikationsrelevanten Testboards erfordert.
- *A: Application level***: Die beschriebene Änderung hat möglicherweise Einfluss auf die Applikation/ das Steuergerät. Die Evaluierung der Änderung wird wie unter C oder B durchgeführt. Zusätzlich ist vom Kunden/Steuergeräthehersteller der Einfluss der Änderung im Steuergerät durch geeignete Untersuchungen zu bewerten. Dieses Vorgehen ist mit dem OEM abzustimmen. Hierbei ist zu berücksichtigen, ob die Steuergeräte- / Baugruppenanforderungen durch andere Qualifikationen bereits hinreichend abgesichert sind (**applikationsspezifische Risikobetrachtung**).
- ** : Not relevant for qualification matrix***: Änderung(en), die nicht in A, B oder C eingestuft werden können und somit nicht relevant für die DeQUMA sind.

Information Notes

Änderungen die nur eine Information Note benötigen (bei der Bewertung Risk on Supply Chain als "I" gekennzeichnet), dürfen nicht in der DeQuMa angekreuzt werden, da Sie ansonsten den erforderlichen Evaluierungslevel verfälschen. Für als "I" bewertete Änderungen ist das Information Note Formblatt zu verwenden.

Wichtige Hinweise

- Zur formgerechten Anwendung der DeltaQualifikationsMatrizen steht auf der Homepage des ZVEI AK ein Tutorial bereit (ZVEI-Tutorial).
- ID Nummer: ist eine eindeutige Identifikationsnummer für jede angegebene Änderung, die in den ZVEI PCN DeltaQualifikationsMatrizen identifiziert ist. Die gleiche ID Nummer wird zur Identifizierung der Änderung im PCN Form Sheet verwendet.
- Die mittels Matrix identifizierten Tests sind in **Betracht zu ziehen**, d.h. es ist zu prüfen, ob der jeweilige Test für die spezifische Änderung in dieser Form notwendig ist. Abweichungen oder generische Daten sind im Detail zu begründen.
- Die Spalte "Further applicable conditions", Bemerkungen und Fußnoten sind unbedingt zu beachten, da sie wichtige Hinweise und Einschränkungen enthalten.
- Zur Nutzung aller Funktionen muss in Excel die Anwendung von Makros freigegeben sein.

Form provided by ZVEI - Revision 3.1 - December 2016

DeltaQualificationMatrix

General

Short product and technology cycles as well as new environmental regulations („Pb-free“, flame retardants, ...) frequently result in process and material changes of components, printed circuit boards, assembly techniques and circuit layout which have to be evaluated. The ZVEI "Guideline for Customer Notifications of Product and /or Process Changes (PCN) of Electronic Components specified for Automotive Applications" describes an appropriate methodology for dealing with changed electronic components. The qualification matrices in this guideline are recommendations for how to assess typical changes of electronic components. These recommendations promote an open risk-based discussion between supplier and customer regarding qualifications.

The DeltaQualificationMatrices were developed by the Industry Task Force Team "PCN DeltaQualificationMatrix" together with component experts from the ZVEI Working Group "PCN-Methodology". Actual content represents state-of-the-art technology and does not claim to be comprehensive. Deviation from proposed guideline should be mutually agreed as customer specific requirements have to be considered.

DeltaQualificationMatrix Application (completion by component manufacturer)

- This table has to be used for changes **only**. The matrices are not applicable for new product, special qualifications (for instance for encapsulation of module) or Information Notes.
- If a change is not listed in this table, the qualification plan has to be defined and agreed between customer and supplier.
- The matrix for Active Components requires the user to choose between integrated circuits (AEC-Q100 Rev. H) and discrete semiconductors (AEC-Q101 Rev.D1) (cell D4). For Passive Components AEC-Q200 is used. For LED'S the IEC 60810 is used.
- All** changes as listed in the PCN have to be marked by a cross (x) in column B and will appear colored. The relevant reliability tests are then shown in "Tests, which should be considered for the appropriate process change" (row 83 for Active Components, row 466 for Passive Components, respectively in row 77 for LED's).
- In "Tests, which should be considered for the appropriate process change after selection of condition table" (see row 85 for Active Components, row 468 for Passive Components, or row 79 for LED's) is for modification of the found relevant tests under consideration of the weight of change. Related table "Conditions" has to be assessed per proposed letters with an (x).
- In "Suppliers performed tests" (here row 87 for Active Components, row 470 for Passive Components, or row 81 for LED's) the component manufacturer documents the planned and performed tests.
- In case of deviations from tests, which should be considered this should be notified and commented by the component manufacturer in the area "Reason for exception of tests" (see row 89 for Active Components, row 472 for Passive Components, or row 83 for LED's). Test results in form of generic data (G) are allowed when notified and justified.

Evaluation Levels are categorized as follows

- *C: Component level***: The evaluation of a change at component level by the component manufacturer is sufficient. Generic data from other relevant evaluations can be used.
- *B: Board level***: The intended change described in the PCN may influence processability / manufacturability of the component at board level. Therefore additional evaluation by customer may be necessary, for example reliability tests on application relevant testboards, depending on change.
- *A: Application level***: The intended change described in the PCN may influence the properties of the application (e.g. Electronic Control Unit). In addition to the evaluation under C or B the influence of the change in the application is evaluated by suitable investigations by the customer. The scope of the evaluation has to be aligned with the OEM. It has to be considered whether the application / assembly requirements are already sufficiently safeguarded by other qualifications (**application specific risk assessment**).
- ** : Not relevant for qualification matrix***: Changes which fulfill neither A,B nor C definitions

Information Notes

Changes indicated as "I" shall not be marked in the DeQuMa. For those changes the InformationNote sheet shall be used. As the DeQuMa is desired for PCN only, a marking of "I"-changes would automatically influence evaluation level and test effort.

Important Notes

- To use the matrices in the right form the ZVEI working group provides a Tutorial on its homepage (ZVEI-Tutorial)
- ID number: is a unique identification number for each indicated change defined in the ZVEI PCN DeltaQualificationMatrices. The same ID number is used in the PCN Form sheet to identify the change.
- Tests identified by the matrix have to be **considered** and checked if they are necessary to assess the specific change. Test modifications or generic data have to be justified in detail.
- "Further applicable conditions", comments and notes need attention, as they provide important hints and limitations.
- In order to use all functions in EXCEL, macros have to be allowed.

History of DeQuMa

Version	Remarks
2.0	Revised by ZVEI PCN Methodology Workgroup in March 2015
2.1	Released March 2015
2.1.1	Active Components - delete write protection in comments
2.2	Solved problems with some ActiveX configurations
2.2.2	Solved Problems in Active Components
2.2.3	Solved Problems ActiveX, Active Components SEM-DE-02 (Design changes in routing) error fixed
2.2.4	Minor fixes
3.0	General Revision by ZVEI PCN Methodology Workgroup in June 2016 Changes are indicated by underlining in the read only version named Changes_DeQuMa_rev3_vs_rev2.xlsx
3.0.4	Expert Release
3.0.5	Fixing of macro bugs
3.1	Final Release (orthographic and punctuation corrections)

Change ID	Change Description	Category	Impact	Priority	Requirement	Material	Process	Equipment	Software	Documentation	Testing	Validation	Approval	Implementation	Rollback	Other
PAS-QU-PR-02	Dry pack requirements change	P	P	P	Change of dry pack requirements	e.g. change of MSL e.g. change of dry pack assurance (PIC, MBS)	B									
PAS-QU-PR-03	Change of carrier tray, rest	P	P	P	Change of carrier	e.g. change by material e.g. change by geometry	B									
PACKING / SHIPPING - VISUAL INSPECTION																
PAS-QU-PIV-01	Change of labelling	I	P	P	Change of labelling, also on rest	It is a withdrawal information that is shared It is a change of customer specific information	B									
PAS-QU-PIV-02	Change of product marking	I	P	P	Marking on device	e.g. change of content of marking e.g. change of method of marking e.g. change of assurance of marking	B									
PAS-QU-PIV-03	Change of packaging/shipping specification	P	P	P	Change in packing specification which does not describe a change of dimensions or material of the packing	e.g. change of documentation in packing specification	-									
LOGISTICS / CAPACITY / TESTING - EQUIPMENT																
PAS-QU-ED-01	Production from a new equipment which uses a different technology or which due to its unique form or function can be expected to influence the integrity of the final product	P	P	P	Change in process technique which is not already covered in the Risk Assessment Note: Changes affecting the product or process by the table require also a POC	e.g. new equipment supplier with different process control	C									Test effort depends on final risk assessment. Performance test according to affected process change
PAS-QU-ED-02	Production from a new equipment which uses the same basic technology (replacement equipment or extension of existing equipment)	I	P	P	POC required for dedicated equipment for sensitive component production	e.g. additional equipment to increase production capacity e.g. replacement of same equipment	C									Test effort depends on final risk assessment. Performance test according to affected process change
PAS-QU-ED-03	Change in final test equipment which use different technology	P	P	P	Change of final test equipment which use different technology POC required for dedicated equipment for sensitive parameters	e.g. change of water platform	C									Gage R&R / Gage combination
LOGISTICS / CAPACITY / TESTING - PROCESSES / PLAN																
PAS-QU-PP-01	Manufacturing site transfer or replacement of a part of production process to a different location	P	P	P	Change of manufacturing site. Note: Manufacturing site transfer one location is not affected	Assessment or transfer of manufacturing site or process only to a different location	B									
PAS-QU-PP-02	Extension or addition of a manufacturing process step	I	P	P	Change of manufacturing process technique	e.g. reworking / changing process e.g. change of order processing	C									Characterization depends on impact of production line
LOGISTICS / CAPACITY / TESTING - G-GATE																
QUA-GE-01	Change of test component used by the supplier to reduce date sheet compliance (e.g. microprocessor or a physical component like flow block, microcontroller) of a new product	I	P	P	Change of test coverage	e.g. change from 100% to sample inspection e.g. test flow block, reduction from 100% to two point test measurement e.g. change in burn in time in process	C									Check: Rework, Test coverage, (re)ability only for change in burn in process
NEW MATERIALS																
PAS-ALL-MAT-01	Any change with impact on processability/manufacturability of customer, which is not covered in the contract	P	P	P	No relevant for technical evaluation		-									
PAS-ALL-MAT-02	Any change with impact on processability/manufacturability of customer, which is not covered in the contract	P	P	P	Technical interface means component terminals. The processability on board level		B									
DATASHEET																
PAS-ALL-DS-01	Change of electrical parameters/electrical specification (Min, Max, Typ, values) and / or AC/DC specification	P	P	P	Change of application relevant information. Supplier or change. No technical change of the product, only variation in description (wording, drawing, ...)	e.g. tighten of electrical parameter distribution	A									Risk assessment depending on change for each application
PAS-ALL-DS-02	Correction of data sheet	I	P	P	It is a case of technical change (PT) in case of impact on product integrity	e.g. data sheet correction because of new information about component behavior	A									
PAS-ALL-DS-03	Specification of additional parameters	I	P	P	Description of a new not products covered parameter. No technical change of the product (PT). Risk assessment depending on change for each application to provide additional parameters (see evaluation)	e.g. adding new tested parameter	A									
MATERIAL																
PAS-ALL-M-01	Change of material composition - Housing	P	P	P	Change of housing	e.g. change Al alloy for housing	C									Be only if a cap holder holds the capacitor body by pressing
PAS-ALL-M-02	Change of material composition - Sealing	P	P	P	Change of sealing	e.g. change of rubber compound e.g. change of welding wire material (lead, Sn/Pb)	C									Be in case of internal surface of sealing is changed. Evaluation only if exposure to gas
PAS-ALL-M-03	Change of material composition - External insulation	P	P	P	Change of external insulation / covering	e.g. change from PVC to PET e.g. change of colour	C									Be Only for glass capacitors
PAS-ALL-M-04	Change of material composition - Lead / Termination	P	P	P	Change of lead or solder termination	e.g. change of leadframe from iron into copper e.g. change of leadframe from lead to lead free	C									Beval: Hermetic seal can be done without apply voltage
PAS-ALL-M-05	Change of material composition - Internal insulation / Paper	P	P	P	Change of paper type / internal insulation	e.g. change of paper thickness 50 µm to 40µm	C									A: Only if impedance increases (delta change expected). Check if dielectric is affected (PAS-ALL-DS-01)
PAS-ALL-M-06	Change of material composition - Electrolyte	P	P	P	Change of electrolyte	e.g. change in formulation	C									A: Only if impedance increases (delta change expected). Check if dielectric is affected (PAS-ALL-DS-01)
PAS-ALL-M-07	Change of material composition - Tape Material	P	P	P	Change of changing tape material	e.g. change of die or base material	C									
PAS-ALL-M-08	Change of material composition - Base Plate	P	P	P	Change of base plate material	e.g. change of used plastic material	B									
PAS-ALL-M-09	Change of supplier of material	I	P	P	Change to a new or additional material supplier at component manufacturer	e.g. for 2nd source purpose	C									Test effort depends on final risk assessment. Performance test according to affected material. Internal specification remains unchanged. Otherwise see change of material
DESIGN																
PAS-ALL-DE-01	Change of termination, surface finish, shape, color, appearance or dimension structure - Wire Connect	I	P	P	Change of wire diameter	e.g. change from 0.8 into 0.6 mm wire diameter	B									
PAS-ALL-DE-02	Change of termination, surface finish, shape, color, appearance or dimension structure - Termination	I	P	P	Change of termination appearance for solder / reflow only	e.g. change from rest to into bright tin	B									
PAS-ALL-DE-03	Change of termination, surface finish, shape, color, appearance or dimension structure - Appearance	I	P	P	Change of appearance. Note: Marking on device is defined as process change (PAS-QU-PIV-02)	e.g. change of color/appearance e.g. change of wire and shape	B									
PAS-ALL-DE-04	Change of termination, surface finish, shape, color, appearance or dimension structure - Rubber Seals	I	P	P	Change of rubber sealing stand-off shape (for solder)	e.g. change of profile / shape	A									
PAS-ALL-DE-05	Change of inner connection - Aluminum Fill	I	P	P	Change of Al fill with	e.g. change of with	B									
PAS-ALL-DE-06	Change of inner connection - Soldering	I	P	P	Change of soldering with	e.g. change of with	C									
PAS-ALL-DE-07	Change of inner connection - Electrical Design	I	P	P	Change of electrical design	e.g. change of resistor design/reliability	C									
PAS-ALL-DE-08	Change of inner connection - Inner Connection	I	P	P	Change of inner connection	e.g. change of shape/dimension	C									Terminal Strength (1) not for axial components without paddle film
PAS-ALL-DE-09	Change of inner connection - Changing Type	I	P	P	Change of changing type	e.g. change of dimension	C									
PAS-ALL-DE-10	Change of inner connection - Fill	I	P	P	Change of fill type	e.g. change of wetting level e.g. change of thickness	C									
PROCESS																
PAS-ALL-PR-01	Changes in process technology or manufacturing methods - Terminal Attach	I	P	P	Change of terminal attach process	e.g. change of wetting / reflow layout	C									Terminal Strength (1) and Voltage (1) not for axial components without MBS/MS
PAS-ALL-PR-02	Changes in process technology or manufacturing methods - Winding	I	P	P	Change of winding process	e.g. change of material composition	B									
PAS-ALL-PR-03	Changes in process technology or manufacturing methods - Impregnation	I	P	P	Change of impregnation	e.g. change of fill process into industrial application	C									Surge voltage test for high voltage components only
PAS-ALL-PR-04	Changes in process technology or manufacturing methods - Assembly	I	P	P	Change of assembly process	e.g. change of reflow method e.g. change of assembly process assistance	C									
PAS-ALL-PR-05	Changes in process technology or manufacturing methods - Aging / Testing	I	P	P	Change of aging/testing process	e.g. change of aging, voltage or temperature of process	C									Di. Depends on process change
PAS-ALL-PR-06	Changes in process technology or manufacturing methods - Tin & Form Lead	I	P	P	Change of tin & form process (lead)	e.g. change of holding shape or bonding procedure	B									Substability may be influenced
PAS-ALL-PR-07	Changes in process technology or manufacturing methods - Tin & Form SMD	I	P	P	Change of tin & form process (SMD)	e.g. change of holding shape or bonding procedure	B									Substability may be influenced
PAS-ALL-PR-08	Process tightly, tuning with specification	I	P	P	Variation within process specification	e.g. process control	C									
PACKING / SHIPPING - NEW MATERIAL, CRITICAL DIMENSIONS																
PAS-ALL-PIV-01	Packing / shipping specification change (dimension of tolerances)	P	P	P	Change of packing specification	e.g. number of pieces on rest	B									
PAS-ALL-PR-02	Dry pack requirements change	P	P	P	Change of dry pack requirements	e.g. change of MSL e.g. change of dry pack assurance (PIC, MBS)	B									
PAS-ALL-PR-03	Change of carrier tray, rest	P	P	P	Change of carrier	e.g. change by material e.g. change by geometry	B									
PACKING / SHIPPING - VISUAL INSPECTION																
PAS-ALL-PIV-01	Change of labelling	I	P	P	Change of labelling, also on rest	It is a withdrawal information that is shared It is a change of customer specific information	B									
PAS-ALL-PIV-02	Change of product marking	I	P	P	Marking on device	e.g. change of content of marking e.g. change of method of marking e.g. change of assurance of marking	B									
PAS-ALL-PIV-03	Change of packaging/shipping specification	P	P	P	Change in packing specification which does not describe a change of dimensions or material of the packing	e.g. change of documentation in packing specification	-									
LOGISTICS / CAPACITY / TESTING - EQUIPMENT																
PAS-ALL-ED-01	Production from a new equipment which uses a different technology or which due to its unique form or function can be expected to influence the integrity of the final product	P	P	P	Change in process technique which is not already covered in the Risk Assessment Note: Changes affecting the product or process by the table require also a POC	e.g. new equipment supplier with different process control	C									Test effort depends on final risk assessment. Performance test according to affected process change
PAS-ALL-ED-02	Production from a new equipment which uses the same basic technology (replacement equipment or extension of existing equipment)	I	P	P	POC required for dedicated equipment for sensitive component production	e.g. additional equipment to increase production capacity e.g. replacement of same equipment	C									Test effort depends on final risk assessment. Performance test according to affected process change

AD8417 Data Sheet Changes from Rev. C to Rev. D

Change to Revision History on Page 2

Add:

REVISION HISTORY

6/2019—Rev. C to Rev. D

Changes to Features Section.....	1
Changes to Table 3.....	4
Changes to Figure 33.....	13

Changes to Features Section on Page 1

Rev C

High common-mode input voltage range

-2 V to +70 V continuous

-4 V to +85 V survival

Rev D

High common-mode input voltage range

-2 V to +70 V continuous

-3 V to +80 V survival

AD8417

Rev C

ABSOLUTE MAXIMUM RATINGS

Table 3.

Parameter	Rating
Supply Voltage	6 V
Input Voltage Range	
Continuous	-2 V to +70 V
Survival	-4 V to +85 V
Differential Input Survival	±5.5 V
Reverse Supply Voltage	0.3 V
ESD Human Body Model (HBM)	±2000 V
Operating Temperature Range	
AD8417WB	-40°C to +125°C
AD8417WH	-40°C to +150°C
Storage Temperature Range	-65°C to +150°C
Output Short-Circuit Duration	Indefinite

- ← Remove Line: this is operating range...not AMR.
- ← Modify Parameter name for clarity, fix rating values.
- ← Shorten & indent Parameter name for clarity, add clarity to rating.



AD8417

Rev D

ABSOLUTE MAXIMUM RATINGS

Table 3.

Parameter	Rating
Supply Voltage	6 V
Input Voltage Range	
Common-mode	-3V to +80V
Differential	5.5 V (Magnitude)
Reverse Supply Voltage	0.3 V
ESD Human Body Model (HBM)	±2000 V
Operating Temperature Range	
AD8417WB	-40°C to +125°C
AD8417WH	-40°C to +150°C
Storage Temperature Range	-65°C to +150°C
Output Short-Circuit Duration	Indefinite

Changes to Figure 33 on page 13

Rev. C

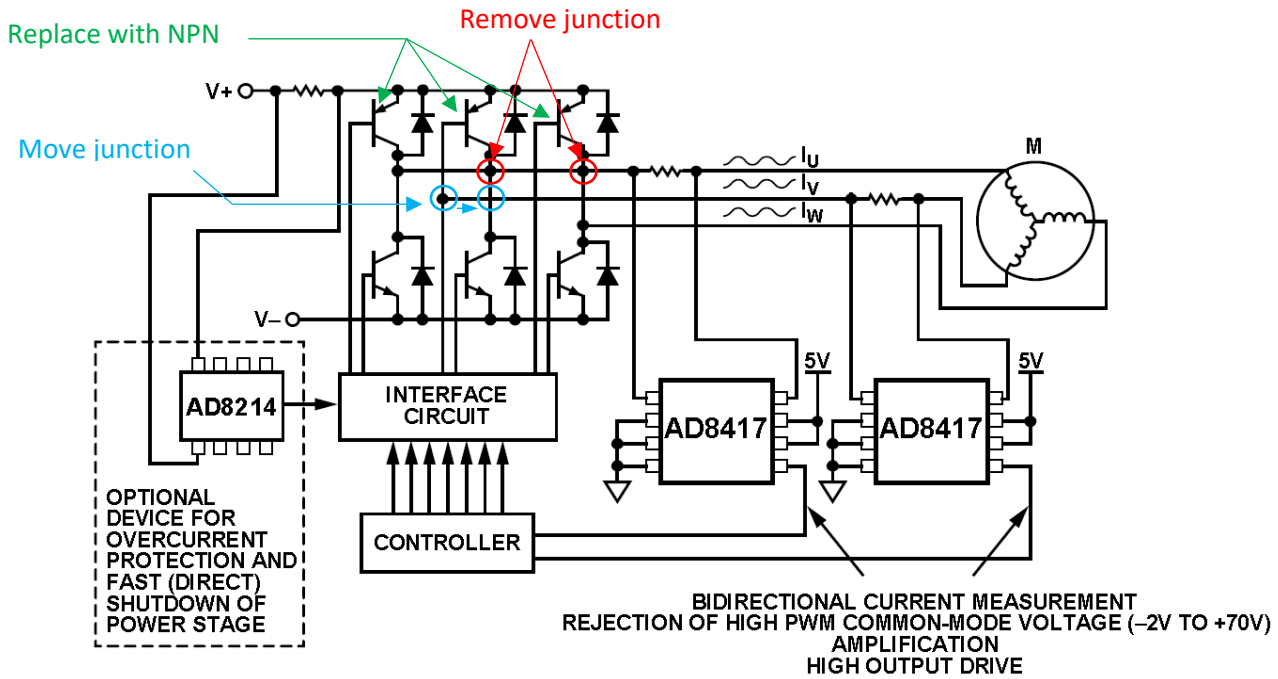

Figure 33. 3-Phase Motor Control

Rev. D

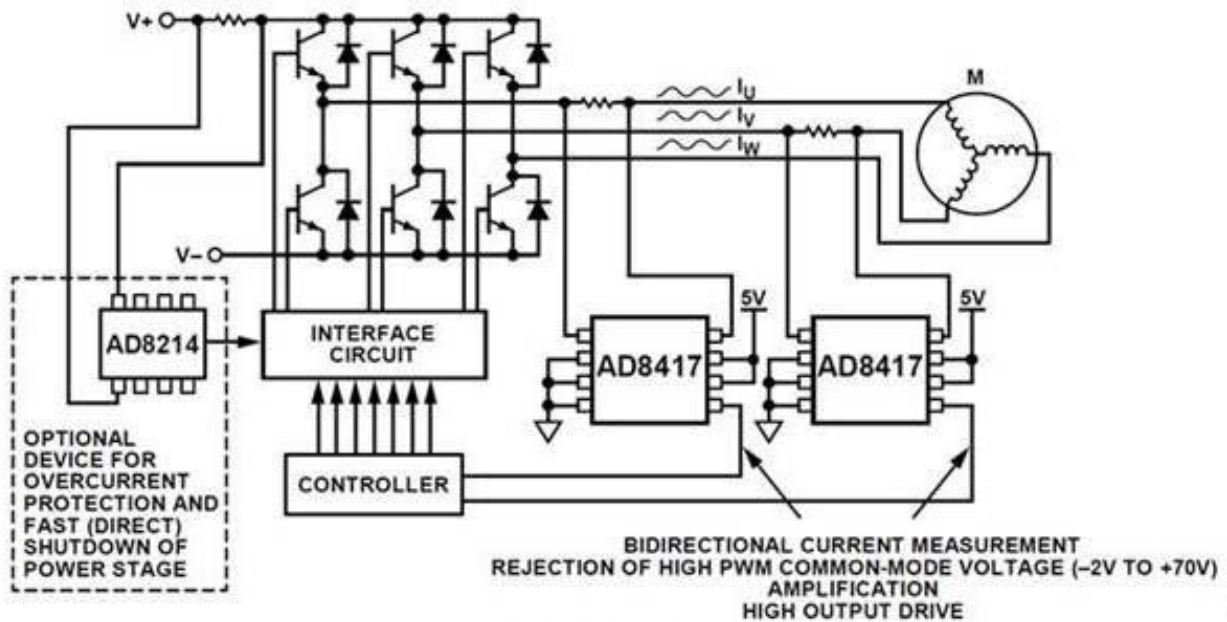

Figure 33. 3-Phase Motor Control